

Measurement of viscosity of fused salts. I. Method of measurement. Viscosity of Li_3AlF_6 and Na_3AlF_6

I. VOTAVA and K. MATIAŠOVSKÝ

*Institute of Inorganic Chemistry, Slovak Academy of Sciences,
809 34 Bratislava*

Received 9 August 1971

The theory of the damped oscillation of an oscillating body is discussed with regard to the determination of the viscosity of fused salts. The absolute and relative methods of viscosity measurements using the torsion pendulum method were analyzed. The possibility of application of a simple dependence, which makes possible to calibrate the apparatus using a single series of liquids in the relative viscosity measurements, was verified. The results were compared with those obtained by the absolute method.

The oscillating torque viscosimeter for the measurement in the high-corrosive low-viscosity melts up to 1200°C is described. The reproducibility of the measurement was $\pm 1.5\%$. In order to determine the suitability of the experimental arrangement, the viscosities of the reference substances, both of the aqueous solutions and of the fused salts, were determined. The results confirmed the suitability of the proposed scheme in the estimated interval of viscosities.

Using the tested apparatus, the viscosities of molten Li_3AlF_6 and Na_3AlF_6 in the temperature range $900\text{--}1100^\circ\text{C}$ and $1040\text{--}1170^\circ\text{C}$, respectively, were measured.

The coefficient of the internal friction — viscosity — appears to be one of the most characteristic properties of liquids. With regard to the high sensitivity of viscosity to the structural changes in the liquid (the melt), the experimental measurement of viscosity is one of those methods, which are used for the determination of the structure of fused salts, especially for the determination of the association and dissociation of the components, for the determination of the complex formation in the melt, *etc.* The study of viscosity of molten salts is interesting also with regard to the large application of fused salts in technical electrolysis, mainly in the field of the electrometallurgy of light metals. Here, the knowledge of viscosity of the melt is indispensable in the analysis of the hydrodynamic processes, which take part in the electrolysis. These processes determine the convection and the mixing of the electrolyte, the transport of the anode gases to the surface of the melt, the sedimentation of the Al_2O_3 particles in the electrolyte, *etc.*

In the experimental determination of the viscosity of cryolite melts, the high temperature of the primary crystallization of the respective samples (above 1000°C) and the high chemical reactivity are to be taken into account. In the construction of the measuring apparatus, beside the high temperature of the primary crystallization, the corrosive and the surface properties, as well as the relatively high vapour pressure of the studied molten mixtures, also the high accuracy (approx. $\pm 1.5\%$), which is required in the determination of viscosities in the range $1\text{--}8$ cP, must be considered.

For the measurement of the viscosity of the low-melting compounds, in some cases the capillary method was used [1, 2], mainly the viscosimeter proposed by Ostwald [3] and Ubbelohde [4]. However, at high temperature the application of this method is complicated with regard to the possibility of a change of the capillary diameter caused by corrosion, or by surface recrystallization of the capillary material. Therefore, for the viscosity measurements in the low-viscosity high-melting compounds and mixtures so far only rotation methods are used, namely the torsion pendulum methods based on the damping of the harmonic oscillations of a suitable pendulum. The pendulum consists of a sphere [5–9], a disc [10], an ellipsoid [11] or a cylinder [6], or of a hollow cylinder or a sphere filled with the melt [12, 13]. In most cases, a spheric pendulum oscillating in the melt in a stable crucible is used. The theoretic basis of this method was elaborated by *Verschaffelt* [8], *Dantuma* [5], and *Barr* [14] and later perfected by *Abramov* [7]. The pendulum consisting of a sphere is suspended on a metallic file which is fixed in a device providing a suitable deflection of the pendulum from an equilibrium position. After the deflection, the pendulum effectuates the harmonically damped oscillations, the amplitude being given by the equation

$$A = K e^{-\delta \frac{t}{T}} \cos 2\pi \frac{t}{T}, \quad (1)$$

where A is the amplitude of the oscillation (in radians),

t is the time (s),

T is the period of a harmonic oscillation (s),

K is a constant (in radians),

δ is the logarithmic decrement.

The period of the harmonic oscillation T , and the logarithmic decrement δ do not depend on the amplitude A and the time of oscillation t , since they are functionally dependent on the inertia properties of the pendulum system, the friction properties of the file, the viscosity and the density of the melt. The viscosity was calculated using the experimentally determined T , δ and the density values. Denoting the amplitudes of the k -th and the $(k+n)$ -th oscillation as A_k and A_{k+n} , the logarithmic decrement of the damped oscillation can be expressed by means of the equation

$$\delta = \frac{\ln A_k - \ln A_{k+n}}{n}. \quad (2)$$

Since the logarithm of an amplitude is linearly dependent on the number of the oscillation, this dependence was utilized for a graphic refinement (approximation) of the values of amplitudes in the calculation of the logarithmic decrement.

Principally, the viscosity can be calculated by two different methods. Approximately, it can be calculated using the equation

$$\delta - \delta_0 = c_1 \sqrt{\rho \eta} + c_2 \eta + c_3 \rho \eta, \quad (3)$$

where δ_0 is the logarithmic decrement of the damped oscillation in the air,

ρ is the density of the melt (g cm^{-3}),

c_1 , c_2 , and c_3 are constants which are characteristic of the applied apparatus.

In the calculation of the viscosity by this method, the constants c_1 , c_2 , and c_3 are to be determined by calibration of the apparatus using the melts with exactly determined η and ρ values. Here, the choice of suitable melts is strongly limited since the literature

data on the density and viscosity of substances which would cover the entire investigated range are very scarce. Besides, in the above equation the correction corresponding to the thermal dilatation of the pendulum at high temperatures is not considered.

The second method eliminates the deficiencies of the first one. For a sphere oscillating in a melt, the following kinetic differential equation was derived for the movement of a spheric layer [8]

$$\frac{\partial \omega}{\partial r^2} + \frac{4}{r} \frac{\partial \omega}{\partial r} - \frac{\rho}{\eta} \frac{\partial \omega}{\partial t} = 0. \quad (4)$$

Derivating the equation (4), we obtain an equation in which the viscosity appears to be a function of measurable quantities. In the first step, an approximate value of viscosity is calculated using the relation

$$\sqrt{\eta} = \frac{(T - T_0) K}{T_0^2 R^4} \sqrt{\frac{T}{\pi \rho}} \quad (5)$$

and the calculated viscosity value is used in the evaluation of the terms

$$b = \sqrt{\frac{\pi \rho}{\eta T}} \quad \text{and} \quad P = \frac{b R + 1}{(b R + 1)^2 + b^2 R^2}.$$

The values b and P were substituted in the final formula for the calculation of the viscosity

$$(2 + P) \eta + R \sqrt{\frac{\pi \rho}{T}} \sqrt{\eta} - \frac{3}{4} \cdot \frac{\delta K}{T_0 R^3 \pi} = 0, \quad (6)$$

where ρ is the density of the melt (g cm^{-3}),

T_0 is the period of the oscillation in the air (s),

T is the period of the oscillation in the melt (s),

R is the diameter of the oscillating sphere (cm),

K is the momentum of inertia of the oscillating system (g cm^2),

δ is the logarithmic decrement.

The above equation can be applied only if a spheric oscillating body is used. At the same time, the values of K and δ cannot be used without supplementary corrections. The average error in the determination of the viscosity values by means of this method was found to be $\pm 1.5\%$.

A simplified method using a nomogram for the determination of the dependence of δ on η and ρ was proposed by *Abramov et al.* [7]. In this case, the average error in the measurement of the viscosity is approx. $\pm 3\%$.

Experimental

Apparatus

In Fig. 1, the scheme of the functional part of the measuring apparatus is presented. The schemes of the pendulum and of suspending system are presented in Fig. 2.

A bright Pt sphere ($r^{20^\circ} = 10.19$ mm) 31 was welded on a Pt10Ir rod 32 ($d = 1.5$ mm, $l = 400$ mm) which was fixed to a duraluminium rod 33 ($d = 6$ mm, $l = 270$ mm). This solid part of the pendulum was suspended on a molybdenum torsion wire 34

($d = 0.1$ mm, $l = 58$ cm). On the duraluminium rod, two plane mirrors, 8 and 11, were fixed. The lower mirror served for the determination of the pendulum oscillations whilst the top mirror reflected the light beam which limited the maximum and minimum amplitude of oscillation by means of three photodiodes 1PP75 of the automatic unit. Beside the mirrors, two Al discs, 7 and 10, were attached at the duraluminium rod. The top disc served for an automatic deflection of the pendulum to the maximum amplitude using an adapted standard electrometer 6. The lower disc served as a support for brass discs, which were used as a load to vary the moment of inertia of the pendulum 9. The starting deflection of the pendulum was realized either automatically or manually using the spring device at the top of the pendulum carrier 1. The molybdenum file 24 was thermostated in two steps, using a polystyrene and an air thermostat 4. The working temperature of the file was kept constant at $24 \pm 0.1^\circ\text{C}$.

The oscillations of the pendulum were registered by means of a reflected light beam using an adapted photoresistor detector of the automatic recorder. The recording device consisted of an $x-y$ recorder BAK 21 and an adapted optical curve follower OSK 20, and was situated in a distance of 120 cm approximately from the reflecting mirror. The width of the recording strip was 230 mm. The maximum amplitude was 200 mm, this corresponding to a deflection angle of approx. 30° , however, in the graphical evaluation only the range from 6 to 12° was considered.

As a container, a Pt crucible 25 ($d = 48$ mm, $h = 50$ mm) was found to be fully satisfying with regard to the condition of the decaying oscillation calculated on the basis of the wavelength of the oscillation.

In the construction of the measuring device, the standard resistance furnace [15] with adapted top and bottom parts was used. The furnace consisted of a vertical degussite tube 26 with a Kanthal A 1 heating element 27. The furnace jacket was water-cooled. In spite of the simple coiling of the resistance wire, no increase in damping due to the virial currents in the Pt pendulum were observed. The temperature was regulated and kept constant using a contact-free oscillating regulator, type R, combined with a compensating temperature recorder EZ-2 17. The homogeneous temperature field in the working part of the furnace was provided by shunting the separate parts of the heating element 14. In the investigated temperature interval ($700-1100^\circ\text{C}$), the temperature was kept constant within $\pm 1^\circ\text{C}$. The temperature was measured using a Pt/Pt10Rh thermocouple, the hot junction being placed directly in the melt.

A sheet-iron condenser 12 was placed at the top of the furnace 30 in order to minimize the evaporation of samples.

The measurements were carried out in an argon or nitrogen atmosphere, keeping an overpressure of approx. 50 mmH₂O of the inert gas in the furnace.

Further, a device 23 [16] for an automatic evaluation of the logarithmic damping decrement was constructed. This device fulfilled the following requirements:

- deflection of the pendulum at a definite constant angle when the amplitude of the damped harmonic oscillation sinks below a definite minimum value,
- limitation of the maximum and minimum amplitude of the oscillation,
- digital registration of the number of oscillation between the maximum and the minimum amplitude,
- registration of the number of deflections, *i.e.* the number of independent measurements,
- possibility of choosing the number of independent measurements, after which the system gets into the initial position.

In Fig. 3, the scheme of the logical circuit of the automatic unit is presented. The device

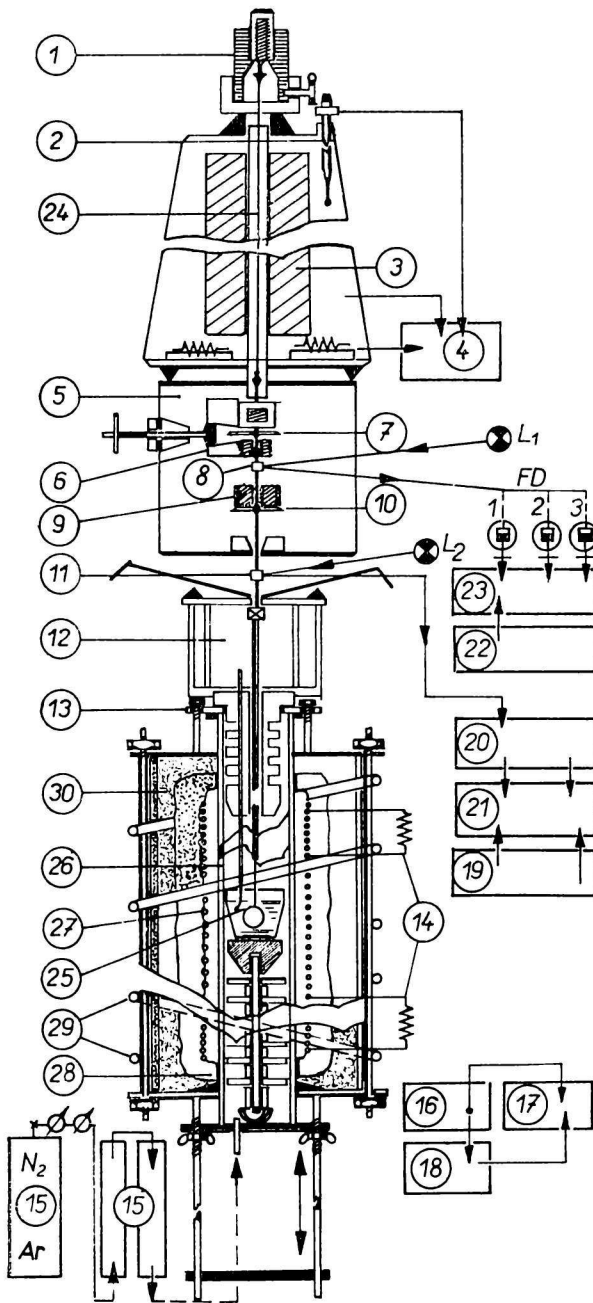

Fig. 1

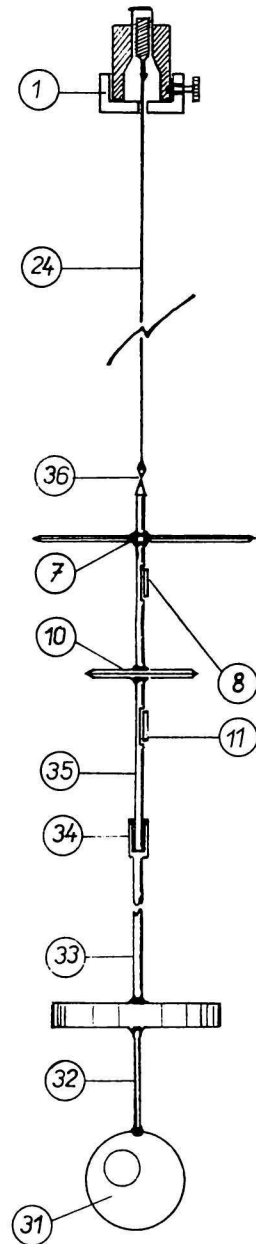

Fig. 2

functions by means of a system of three photodiodes (1PP75) and a logical circuit. In this arrangement, the basic condition of an exact measurement appears to be a sufficiently high number of oscillations between the maximum and the minimum amplitude. The higher is the number of oscillations in a given interval, the slower is the decrease of the amplitudes of oscillations and the more exact is the determination of the minimum amplitude and consequently of the logarithmic decrement. The decrement calculated in this way differs from the value determined by means of the graphical refinement method only by $\pm 0.3\%$, this being a sufficient accuracy in the standard measurement of the viscosity of fused salts.

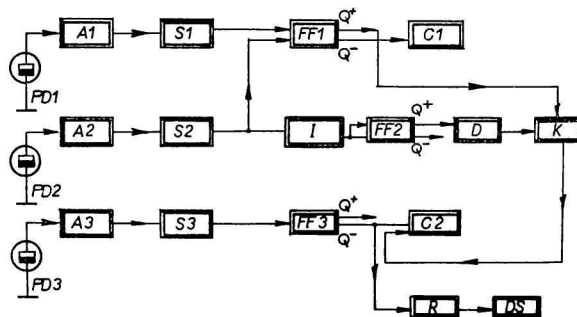

Fig. 3. Scheme of the logical circuit of the automatic unit A1, A2, A3 — amplifiers; PD1, PD2, PD3 — photodiodes; FF1, FF2, FF3 — flip-flop; R — relé connecting the deflection system; D — derivating member; K — key; DS — deflection system; C1, C2 — counters; I — integrator; S1, S2, S3 — Schmitt trigger.

The amplitude T_0 and T was measured by means of a universal counter Tesla BM 354. The determination of the amplitudes of 15 oscillations was found to be highly sufficient to reach the desired accuracy (order of magnitude 10^{-3} s). The time data were measured with an accuracy of $\pm 0.4 \times 10^{-3}$ s.



Fig. 1. Scheme of the apparatus.

1. device for the manual deflection of the pendulum; 2. protecting tube of the torsion file; 3. polystyrene jacket (thermostat); 4. air thermostat; 5. air-tight closure of the torsion system, the deflecting coils, the additional load and of the photodiodes; 6. deflecting coils; 7. deflecting disc; 8. reflecting mirror for the photodiodes circuit; 9. additional load; 10. lower disc (support); 11. reflecting mirror for a direct record of amplitudes; 12. sheet-iron condenser; 13. cover of the furnace; 14. subsidiary resistance for shunting the separate parts of the heating element; 15. argon inlet; 16. feeding part of the heating element; 17. temperature control; 18. thermostatic device; 19. and 22. voltage stabilizers; 20. optical curve follower OSK; 21. $x-y$ recorder BAK; 23. automatic unit of the torsion system including the counter; 24. Mo torsion file; 25. Pt crucible in the working position with the dipped Pt sphere and thermocouple; 26. degussite tube; 27. heating element; 28. insulation; 29. cooling coil; 30. furnace.

Fig. 2. Scheme of the pendulum.

1. device for the manual deflection; 7. deflecting Al disc; 8. reflecting mirror; 10. lower disc (support); 11. reflecting mirror; 24. Mo torsion file; 31. Pt sphere; 32. Pt10Ir rod; 33. Pt10Ir rod with a Pt jacket; 34. duraluminium junction; 35. duraluminium rod; 36. adjustable conic junction.

Reagencies

In the calibration of the apparatus, redistilled water, methanol, anal. grade, (Lachema, Brno), the aqueous solutions of saccharose (*Čsl. 2*, Létiva; 20, 30, and 35 wt % solutions), fused KNO_3 , anal. grade, (Lachema, Brno) and NaCl , anal. grade, (Soyuzkhimexport, USSR) were utilized.

In the measurement of the viscosity of Na_3AlF_6 , hand-picked Greenland natural cryolite (m.p. $1006 \pm 1^\circ\text{C}$, fluorine content 54.6%) was used. Li_3AlF_6 was prepared by melting the stoichiometric mixture of LiF for single crystals (VÚM, Turnov, Czechoslovakia) and of sublimated AlF_3 .

Results and discussion

In the calibration of the apparatus and in the determination of the reproducibility of the measured values, the viscosities of water, methanol, and of the aqueous solutions of saccharose were measured. The densities of the saccharose solutions were determined by means of the pycnometric method. For the viscosity of methanol and of the solutions of saccharose, the values listed in handbooks [17, 18] were taken. As comparative density and viscosity data of fused KNO_3 and NaCl in the investigated temperature interval, the values presented by *Murgulescu* and *Zuca* [19] and by *Artsdalen* and *Yaffe* [20] were accepted.

The logarithmic decrement δ was determined by means of the method of graphic refinement (approximations) of the measured values of the logarithm of amplitudes. The period of the oscillation was found to be independent of the amplitude within the experimental error. In the temperature interval 20–1050°C, the following values of $\delta_{2+3}^{\circ\text{C}}$ were determined

$$\delta_{2+3}^{20^\circ} = 0.0036,$$

$$\delta_{2+3}^{400^\circ} = 0.0056,$$

$$\delta_{2+3}^{800^\circ} = 0.0074,$$

$$\delta_{2+3}^{900^\circ} = 0.0082,$$

$$\delta_{2+3}^{1050^\circ} = 0.0098.$$

These values represent the contribution of the non-dipped part of the oscillating system to the damping of oscillations.

In the calculation of δ in the temperature interval 300–1050°C, the calibration relations were applied which, beside the influence of the change of the density of the melt, involved also the influence of the changes of the constants of the apparatus in dependence on the temperature [21]

$$\psi \left(\frac{T\nu}{R^2} \right) = \frac{K T \delta}{R^5 \rho T_0}. \quad (7)$$

In routine measurements using the relative method, this relation can be substituted by a simplified relation

$$\frac{\delta}{\rho} = \varphi(\nu). \quad (8)$$

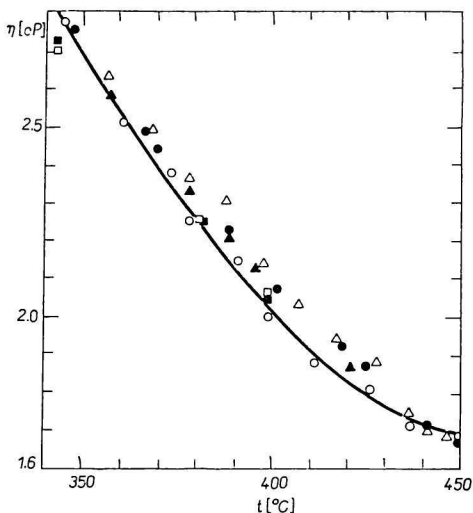

Fig. 4. Polytherm of viscosity of molten KNO_3 .

Δ Lorenz and Kalmus (cited by [5]);
 ● Dantuma [5]; ■ Kleinschmit (cited
 by [5]); □ Dumas et al. [6]; ▲ Murgulescu
 and Zuca [9]; ○ this work.

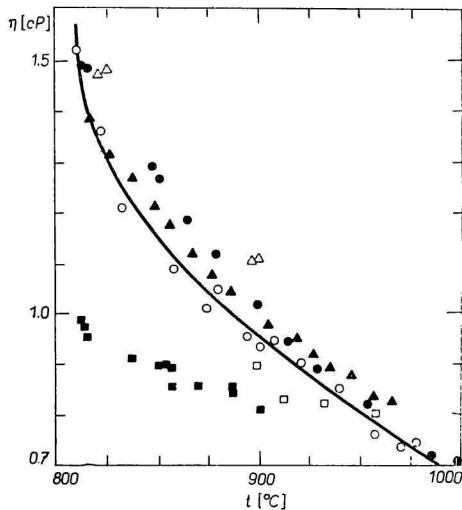

Fig. 5. Polytherm of viscosity of molten NaCl .

● Dantuma [5]; Δ Berenblitt (cited by
 [6]); □ Bondarenko (cited by [6]);
 ■ Dumas et al. [6]; ▲ Murgulescu and
 Zuca [19]; ○ this work.

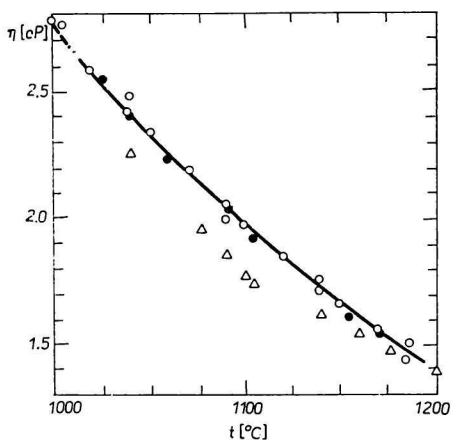

Fig. 6. Polytherm of viscosity of molten Na_3AlF_6 .

● Abramov [7]; Δ Vetyukov and Sipriya
 [25]; ○ this work.

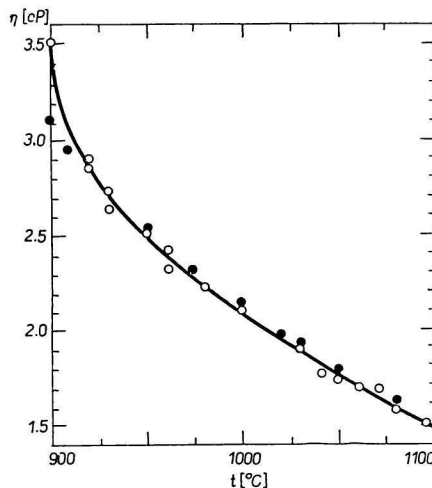

Fig. 7. Polytherm of viscosity of molten Li_3AlF_6 .

● Vetyukov and Sipriya [25]; ○ this work.

In the calculation of the viscosity using the absolute method according to *Verschaffelt* [8], δ_2 was calculated by means of the relation

$$\delta_2 = \frac{K_1 R_2^3 T_2^0}{K_2 R_1^3 T_1^0} \delta_1,$$

where δ_2 is the decrement at the temperature T_2 which differs from the calibrating temperature T_1 . This equation involves the dependence of the constants of the apparatus (the changes of the diameter and hence also of K of the sphere) on the temperature and makes a conversion to an arbitrary temperature possible. Hence, it is not necessary to determine the value of K experimentally in the entire studied temperature interval.

Both in the calculation of the viscosity according to the equation (6) and in the refining calculation, the computer GIER was employed. According to *Dumas et al.* [6], the initial value of the viscosity, applied in the calculation, does not affect significantly the final result and in all calculations the approximate value 0.01 P can be used. However, it was found that in all cases when the estimated initial value differs from the final one by more than $\pm 10\%$, the refinement proceeding is to be performed.

For calculations at medium and high temperatures, KNO_3 and NaCl were taken as reference substances. The experimental results are presented in Figs. 4 and 5. The densities of KNO_3 in the temperature range 336–400°C were calculated according to the equation proposed by *Brillant* [22]

$$d_{\text{KNO}_3} = 2.144 - (0.80 \times 10^{-3}) t,$$

whilst for NaCl the density values reported by *Artsdalen* and *Yaffe* [20] were accepted. In the determination of the viscosity of Na_3AlF_6 and Li_3AlF_6 , the density values presented by *Malinovsky et al.* [23] were used. On the basis of the determined viscosity values, the polytherms of the viscosity of Na_3AlF_6 and Li_3AlF_6 were drawn (Figs. 6, 7).

The temperature dependence of the viscosity of KNO_3 , NaCl , Na_3AlF_6 , and Li_3AlF_6 can be expressed by means of the 2nd degree equation

$$\eta = a + b t + c t^2.$$

Table 1

The values of coefficients a , b , c in the equation $\eta = a + b t + c t^2$ for various molten salts

Substance	a	$b \cdot 10^3$	10^6	Temperature interval [°C]	Ref.
KNO_3	12.547	-41.740	38.978	348–470	This work
NaCl	15.845	-28.428	13.276	816–997	[1]
	14.968	-26.513	12.234	816–997	[3]
	16.545	-27.354	11.600	816–997	This work
Na_3AlF_6	28.880	-42.087	15.996	1020–1170	[3]
	23.829	-33.006	11.938	1020–1170	This work
Li_3AlF_6	26.403	-40.809	16.526	900–1100	[25]
	46.849	-80.620	35.835	900–1100	This work

The values of the coefficients a , b , and c for the above compounds computed using the least-square method, are plotted in Table 1 together with the corresponding values reported in the literature or calculated on the basis of the published data. The equations are valid within the following temperature interval. KNO_3 : 348–470°C, NaCl : 816–997°C, Na_3AlF_6 : 1020–1170°C, and Li_3AlF_6 : 900–1100°C.

The viscosity data presented in this work represent the average values of 35–50 independent measurements. The maximum deviation was $\pm 0.55\%$ in water, methanol, and in the aqueous solutions of saccharose, $\pm 1.15\%$ in molten KNO_3 and $\pm 1.5\%$ molten NaCl , Na_3AlF_6 , and Li_3AlF_6 .

The determined viscosity values of water, aqueous solutions of saccharose, molten KNO_3 and NaCl are in a good agreement with the literature data [18–20], the differences not surpassing $\pm 1.5\%$. The determined viscosities of Na_3AlF_6 agree with those reported by Abramov *et al.* [7] and by Murgulescu and Zuca [24], whilst the data presented by Vetyukov and Sipriya [25] are generally lower by approx. 7%. This difference is still greater in the case of Li_3AlF_6 where the viscosity data reported by Vetyukov and Sipriya [25] are by approx. 12% lower than the corresponding values determined in this work. In both cases, this can be attributed most probably to an inadequate measuring technique in the cited work.

Acknowledgements. The authors wish to express their gratitude to Dr P. Piš (Institute of Machining, Slovak Technical University, Bratislava) and to Dr A. Silný (Institute of Inorganic Chemistry, Slovak Academy of Sciences, Bratislava) for an effective help in the construction of the automatic unit for the determination of the logarithmic decrement.

References

1. Antipin, L. N. and Vazhenin, S. F., *Elektrokhimiya rasplavlennykh solei*, Moscow, 1964.
2. Harrap, B. S. and Heymann, E., *Trans. Faraday Soc.* **51**, 259 (1955).
3. Sundheim, B. R. and Berlin, A., *J. Phys. Chem.* **68**, 1266 (1964).
4. Kenausis, L. C., Evers, E. C., and Kraus, C. A., *Proc. Nat. Acad. Sci.* **49**, 141 (1963).
5. Dantuma, R. S., *Z. Anorg. Allg. Chem.* **175**, 1 (1928).
6. Dumas, D., Grjotheim, K., Høgdahl, B., and Øye, H. A., *Acta Chem. Scand.* **24**, 510 (1970).
7. Abramov, G. A., Vetyukov, M. M., Gupalo, I. P., Kostyukov, A. A., and Lozhkin, L. N., *Teoreticheskie osnovy elektrometallurgii alyuminiya*. Metallurgizdat, Moscow, 1953.
8. Verschaffelt, J. E., *Commun. Phys. Lab. Leiden* **148**, b, c, d (1915); **149**, b (1916); **151** (1917); **153** (1919).
9. Murgulescu, I. G. and Zuca, S., *Z. Phys. Chem.* **218**, 379 (1961).
10. Fawsitt, C. E., *J. Chem. Soc.* **93**, 1299 (1908).
11. MacKenzie, J. D., *Physicochemical Measurements at High Temperatures*. (Edited by Bockris, J. O'M., MacKenzie, J. D., and White, J. L.) P. 313. Butterworths, London, 1959.
12. Shvidkovskii, Je. G., *Nekotorye voprosy vyazkosti rasplavlennykh metallov*. GITTL, Moscow, 1955.
13. Janz, G. J. and McIntyre, J. D. E., *J. Electrochem. Soc.* **109**, 892 (1962).
14. Barr, G., *Viskozimetriya*. Izd. GONTI, Moscow, 1938.

15. Motzfeldt, K., *Physicochemical Measurements at High Temperatures*. (Edited by Bockris, J. O'M., MacKenzie, J. D., and White, J. L.) P. 51. Butterworths, London, 1960.
16. Piš, P., *Automatisace*, in press.
17. *Fisikálně chemické tabulky, I*. Státní nakladatelství technické literatury, Praha, 1953.
18. Hodgman, Ch. D., *Handbook of Chemistry and Physics*, 37th Ed. Chemical Rubber Publishing Co., Cleveland, 1955.
19. Murgulescu, I. G. and Zuca, S., *Izv. Vyssh. Ucheb. Zaved., Tsvet. Metall.* **4** (6) 33 (1961).
20. Artsdalen van, E. R. and Yaffe, D. S., *J. Phys. Chem.* **59**, 118 (1955).
21. Lašek, J., *Čs. Čas. Fys.* **13**, 206 (1963).
22. Brillant, S., *Thèse*. Université de Strassbourg, 1967.
23. Malinovský, M., Paučírová, M., and Matiašovský, K., *Chem. Zvesti* **23**, 27 (1969).
24. Murgulescu, I. G. and Zuca, S., *Acad. Rep. Populare Romine, Studii Cercetari Chim.* **9**, 55 (1961).
25. Vetyukov, M. M. and Sipriya, G. I., *Zh. Prikl. Khim.* **36**, 1905 (1963).

Translated by K. Matiašovský